



TECHNICAL MANUAL

Revision 3, November 2001

IMPORTANT: Read these instructions before installing, operating or servicing this system.

VOYAGER[®] PORTABLE

CEILING LIFT SYSTEM

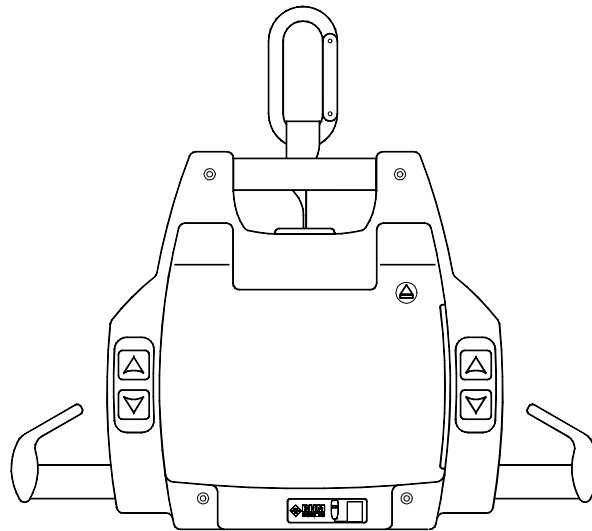

DO NOT DESTROY

BHM Medical Inc. designs and manufactures quality engineered patient lifting equipment for the care of the disabled in hospitals, nursing homes and home care.

Please take the time to read the entire manual, including the section on Safety Instructions and Warnings. It contains important information that will allow you to take advantage of all the characteristics of your BHM patient lift.

BHM Medical Inc. Credentials

- FDA Registration # 9681684
- CE mark (European Union Listing)
- Global Operations for in-warranty and out-of-warranty service support for Voyager Portable lift.
- Each finished Voyager Portable is individually tested in our laboratory.
- Lifting Capacity 200 kg/440 lbs. Engineering safety factor exceeds European Standards.
- Complete range of patient lift slings and supports designed and manufactured by BHM Medical Inc. using medical quality materials and fabrics.
- ISO 9001
- Quick Release US PATENT #6085368 / Patent Pending in other countries.
- Voyager is a registered trademark of BHM Medical inc.

APPROVALS:

CSA 601.1
UL 2601.1
EN 60601.1
EN ISO 10535 (Lifting device) SGS
UK Test Report: DUR22107/AC/OO

Note: BHM Medical is constantly improving its products. For this reason, it may be possible to encounter a modification of product without revision of this guide.

Thank you for trusting your BHM Medical Partners.



How to contact us:

North America:

*BHM Medical Inc.
2001 Tanguay Street
Magog (Quebec)
Canada J1X 5Y5*

Phone: (819) 868-0441

*🕒 service calls during business hours - extension #109
(8:00-12:00 and 1:00-5:00 p.m. E.S.T.)*

*🕒 service calls outside regular business hours
extension #6199 (you must press the pound key)*

Fax : (819) 868-2249

Web site : www.bhm-medical.com

E-mail: bhm@bhm-medical.com

INTRODUCTION 4

 HOW TO USE THIS MANUAL 4

 EQUIPMENT IDENTIFICATION..... 4

 RECEIPT OF EQUIPMENT 4

 KEY TO SYMBOLS 4

SAFETY INSTRUCTIONS AND WARNINGS..... 5

DESCRIPTION OF EQUIPMENT 7

 LIFT UNIT 7

 WHAT’S INCLUDED 7

 PARTS DESCRIPTION7 7

 DIMENSION..... 7

OPERATION..... 8

 HOW TO USE THE VOYAGER PORTABLE 8

BATTERY INFORMATION 10

 CHARGER SPECIFICATIONS #A8200 10

 CHARGING THE BATTERY WITH CHARGER #A8200 10

 CHARGER SPECIFICATIONS #700.13500 11

 CHARGING THE BATTERY WITH CHARGER # 700.13500 12

MAINTENANCE 12

 DAILY CHECK LIST 12

 INSPECTION AND CLEANING..... 13

 STRAP INSPECTION..... 13

 HANDLING AND STORAGE..... 13

 BATTERY REPLACEMENT..... 13

 CHARGER FUSE REPLACEMENT (CHARGER #A8200 ONLY) 14

 ANNUAL INSPECTION..... 14

 STRAP REPLACEMENT 14

 DRUM REPLACEMENT 16

 LIMIT SWITCH REPLACEMENT 17

 LIMIT SWITCH ROD REPLACEMENT 19

 BLOC SSRS REPLACEMENT 19

 MICA REPLACEMENT..... 23

 CIRCUIT BOARD REPLACEMENT..... 24

 TOUCH PAD MEMBRANE REPLACEMENT 25

MAINTENANCE INSPECTION CHECKLIST..... 27

TROUBLESHOOTING 28

ACCESSORIES..... 30

PARTS LIST 31

WARRANTY 37

INTRODUCTION

How to use this Manual



DO NOT ATTEMPT TO USE THIS EQUIPMENT WITHOUT UNDERSTANDING THIS MANUAL.

To ensure safe operation, read carefully the entire manual, especially the section on “Safety Instructions and Warnings”, before installing, operating, or servicing this equipment.

If anything is not completely understood, please contact your supplier for more details. Failure to comply with warnings in this manual may result in injury.

Keep this manual with the lift and refer to it as required. Contents of this manual are subject to change without prior notice to users.

Throughout this manual, the following symbols may appear. Pay particular attention to the information provided under these headings. These special annotations are easily recognized as follows:



WARNING: this symbol is intended to alert the user to hazards or unsafe practices which could result in serious bodily harm.



CAUTION: this symbol is intended to alert the user of the presence of important operating and maintenance instructions, which could prevent product damage or possible personal injury.



NOTE: this symbol offers helpful information concerning certain operating procedures.

Additional copies of this manual can be purchased by contacting your supplier. Include the User Manual product number and equipment identification numbers.

Equipment Identification

The unit's identification number (specification, model, serial number) appears on a silver nameplate attached to the back of base.

Receipt of Equipment

Upon receipt of the equipment, verify it against the packing list to ensure it is complete and inspect the equipment for possible damage due to shipping. If there is any damage, DO NOT USE the equipment and notify the carrier immediately to file a claim. Provide complete information concerning damage claims or shipping errors to your supplier. Include all equipment identification numbers and group part numbers (if any) as described above along with a full description of damaged parts.

Key to Symbols

THE FOLLOWING SYMBOLS ARE USED ON LIFTER'S ATTACHMENT LABELS:



This symbol is required to be displayed on regulated products for sale in the European Market. It indicates that the product complies with applicable European Directives related to health, safety, environment and consumer protection.



Safe Working Load represents the maximum load the lifter is rated for safe operation.

The following symbols are used on sling labels and related to washing instructions:



Maximum washing temperature 60°C (140°F) permanent cycle.



Do not use bleach.



Do not dry clean.



Tumble dry low temperature.



Do not iron.

Please refer to individual sling labels for complete instructions regarding washing and drying.

SAFETY INSTRUCTIONS AND WARNINGS

A. GENERAL

- **IMPORTANT – READ THESE INSTRUCTIONS CAREFULLY OR SERIOUS INJURY MAY RESULT.**
- **KEEP THESE INSTRUCTIONS AND THE KEY PROVIDED WITH THE LIFT AT ALL TIMES.**
- **READ OPERATION AND MAINTENANCE INSTRUCTIONS IN THIS MANUAL BEFORE INSTALLING, OPERATING, OR SERVICING THIS EQUIPMENT.**
- **BHM Medical ceiling lifts are installed by an authorized contractor or installer**
- **Your lift is for transferring patients only. Do not use the lift for any other purpose.**
- **Always carry out the daily checklist before using the lift.**
- **BHM Medical ceiling lifts are specifically designed for BHM Medical ceiling rail systems, slings and accessories. Slings and accessories designed by any other manufacturer are prohibited and will void BHM Medical's warranty. Use only BHM Medical slings and accessories to maintain patient safety and product utility.**
- **BHM Medical ceiling lifts are intended to be used for patients within the specified weight limit indicated for the lift. Do not attempt to lift more than the weight limit indicated.**
- **Before attempting to transfer, the patient must be assessed by a qualified professional.**
- **BHM Medical ceiling lifts must be used by a caregiver with proper training to work with the patient to be transferred.**
- **ONLY trained and qualified caregivers should transfer a patient. DO NOT attempt to use the lift if you have not been properly trained to do so.**
- **ALWAYS be prepared before attempting to transfer a patient.**
- **DO NOT use a sling that is not recommended for the lift.**
- **NEVER use a damaged, torn or frayed sling.**
- **Always place the sling around the patient according to the instructions enclosed.**
- **FOLLOW lifting procedures outlined in this manual.**
- **USE all controls and safety features only according to the rules specified in this manual. Never attempt to force a control or button on the lift.**
- **DO NOT store the charger in a shower, bath or other areas with high humidity.**
- **DO NOT drop the patient lift or battery. Dropping the battery or lift may cause internal damage that is not easily seen. If the lift is suspected to be damaged, take to an authorized technician for servicing.**
- **IMPORTANT: Keep all components of the lift clean and dry, and have electrical and mechanical safety checkpoints done as instructed in the Maintenance section of this manual.**
- **Replace any precautionary or instruction labels that cannot be easily read.**
- **Avoid violent shock during transportation.**

B. SHOCK PREVENTION

- **DO NOT touch or use a lift with bare conductors or a damaged power cord. Electrically live equipment can electrocute a patient. If the lift or charger has any exposed or damaged wires contact your local dealer immediately.**
- **DO NOT cut or remove the round grounding prong from any plug. All BHM lifts are equipped with three-prong plugs to protect from shock hazard or electrocution. Any two-prong electrical outlet must be replaced with a properly grounded three-prong outlet according to the National**

SAFETY INSTRUCTIONS AND WARNINGS

Electrical Code and local codes. It is the responsibility of the customer to have the work done by a qualified electrician.

- Do not splash or expose electric parts of the device to water or moisture.
- Check nameplate for voltage and cycle requirements. These requirements differ by country. Do not attempt to use the lift in an area that has a different voltage and cycle requirement.
- **DO NOT** attempt to expose, service or repair the lift, battery or charger. If any unit is malfunctioning, contact your local dealer.
- **READ** the battery and charger instructions thoroughly before using or storing them.

C. FIRE AND EXPLOSION PREVENTION

- Batteries may explode, leak and cause personal injury if not disposed of properly
 - Do not place or store the battery under direct sunlight or near a heat source
 - Do not dispose of in fire
 - Do not short the battery terminals
 - Do not incinerate
 - Flush with water if electrolyte (Acid) comes in contact with skin or eyes.
- Batteries must be recycled, disposed of according to local law regulations. When returning batteries, insulate their terminals with adhesive tape, etc. Otherwise, the residual electricity in used batteries may cause fire or explosion.



D. EQUIPMENT WARNING LABELS

- Inspect all precautionary labels on the equipment. Order and replace all labels that cannot be easily read.

DESCRIPTION OF EQUIPMENT

Lift Unit

The lift unit is an aluminium frame based system driven by a gear reduced high torque motor.

OPERATING FEATURES

- Ultra-light: 5.45 kg (12 pounds.) battery included.
- Electronic soft-start and soft-stop motor control.
- Easily accessible controls on both sides of the unit.
- Manual emergency lowering device (in case of electrical failure).
- Emergency brake (in case of mechanical failure). Operates on the same principle as a car safety belt mechanism.
- *Quick-Release* feature allows very fast winding and unwinding of the strap before and after transfer operation.
- *Anti-crush* feature stops the lift when there is no tension on the strap, avoiding any injury to the patient. This feature also prevents the strap from getting twisted inside the machine.
- Current limiter for circuit protection in case of overload.
- Low battery disconnect system to protect batteries from been drained.
- Lifting speed: 4 cm/sec. (1.6 in./sec.).
- Strap length up to 2.2 m (88 inches). Tested for 1363.6 kg (3000 lbs.)
- CSA No. 601.1, UL No. 2601-1 and CE certifications.
- Respects EMI standards.

What's included

ITEM	QTY
Voyager lift	1
Battery	1
Charger	1
Power cord	1
4 mm Allen key	1
Instruction manual	1

Parts Description

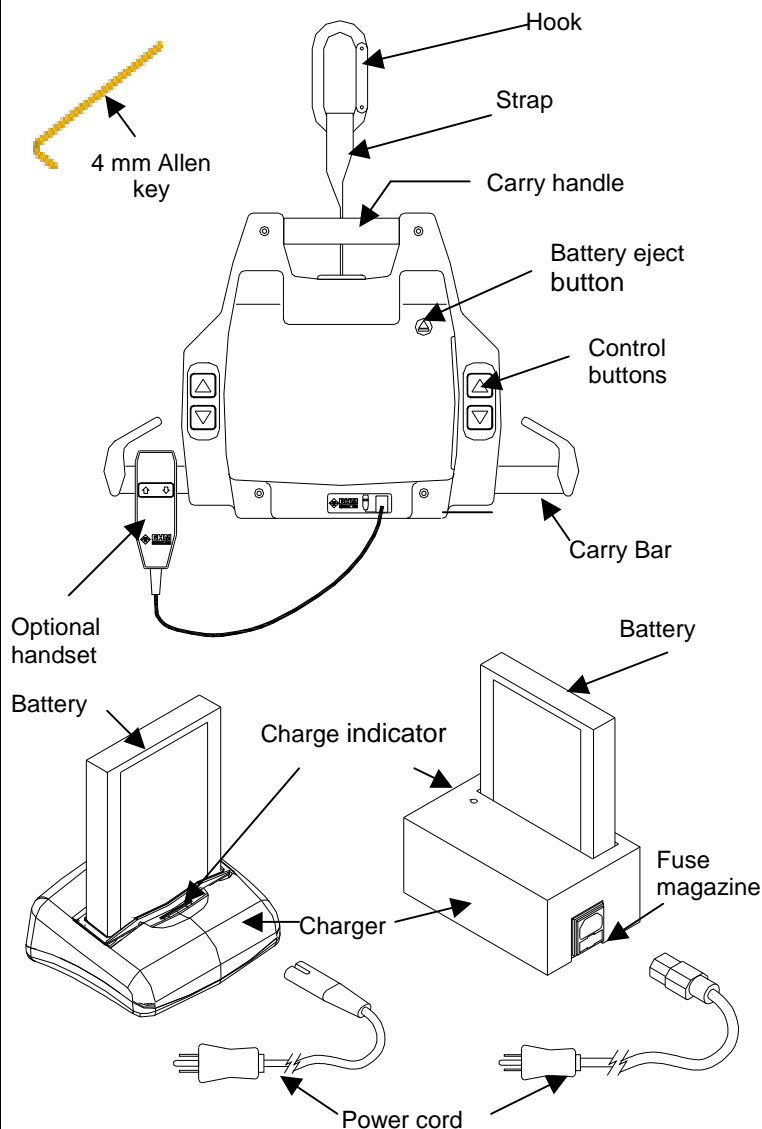

Dimension

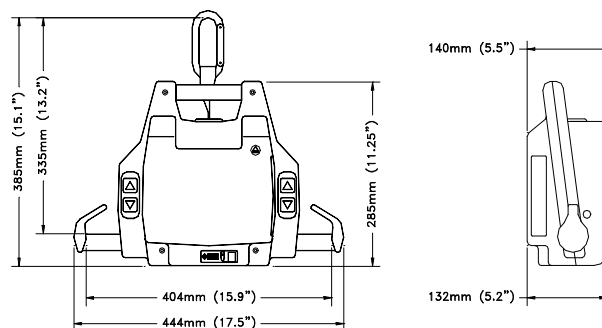

OPERATION

How to use the Voyager Portable



READ "SAFETY INSTRUCTIONS AND WARNINGS" BEFORE ATTEMPTING TO USE THE VOYAGER LIFT.

Always carry out the daily checklist before each lift use.



Damage to the lift may occur if not properly handled. Carry the VOYAGER PORTABLE by its handle only. Do not carry the lift with the arm extension accessory or other accessory not intended to be used to carry the lift.

1. Install the patient sling.
2. Take the battery out of the charger and insert it into the lift. Make sure the silver contact points go inside the lift.
3. Once the patient sling is installed, unwind the strap.

There are two ways to unwind the strap:

First, you can press the  button while holding tension on the strap with the other hand (there must be tension on the strap for the lift to function).

The other way to do this is to use the "QUICK-RELEASE"; Push the knob (1) and pull the strap out of the lift (2).



Push knob completely over to ensure the QUICK-RELEASE will work properly.



QUICK-RELEASE will not work if there is tension on the strap. Make sure the strap has some slack in it before attempting to slide the knob over.

DO NOT force the knob. It should slide easily.

4. Attach the round hook to the trolley in the track.



To help you reach the trolley, use the arm extension as follows:

Insert the round hook into the loop of the arm extension #A8300 (1), then hook it to the trolley in the track (2).

(1)

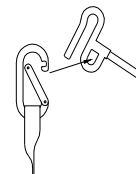

(2)

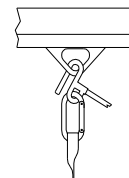

5. Move the lift over to the patient.



Hold the lift with one hand at all times when near a patient.

6. Lower the lift below the chin before beginning to attach the sling straps (this is to avoid the risk of facial contact caused by movement of the lift).

For a patient in a lying position, lower the lift near the thorax, and then install the straps.

7. Attach the straps of the sling for the sling to be used.
8. Lift the patient slightly by pressing the control button .





BEFORE LIFTING THE PATIENT:

1. Make sure that all straps are attached to the carry bar.
2. Make sure the patient's arms are safely out of the way.
3. Make sure the sling is not caught on an obstruction (wheelchair brake or arm of chair).

If any of the above occur – lower the patient immediately and correct the problem.

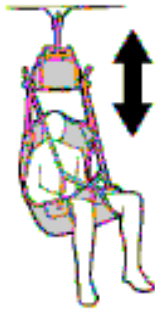
9. Lift until the patient's buttock clears the arm supports or the top of the bath or bed before moving the patient. Guide the legs past any obstacle.



10. When the patient is located above the desired point of transfer and ready to be lowered, press the  button.

11. Use the handles on the back of the sling to position the patient when transferring into a chair. Hold the handles firmly as the sling lowers and the sling will tilt back to position the patient.

12. Once the patient is properly seated and the straps are loose, remove the sling from the lift.

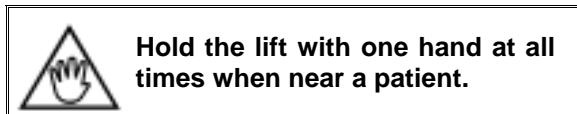

13. Slide the lift away from the patient.

14. Unhook the lift from the trolley in the rail and use the "QUICK RELEASE" to shorten the strap. To do so, push the knob (1) and hold the strap while it winds itself into the lift.

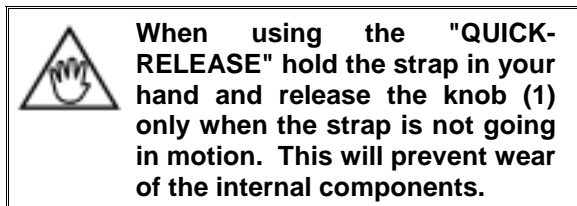
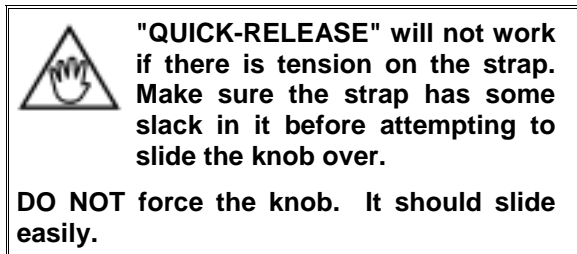
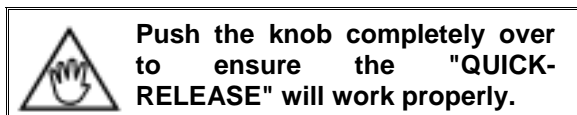

15. The sling may be removed from around the patient.

Emergency Lowering Feature

In the event of an electrical or functional failure, the Voyager Portable has an emergency manual-lowering feature.

If the lift malfunctions when a patient is being transferred, the emergency manual lowering device provides a safe way of lowering the patient onto a chair or bed.

To operate the emergency lowering feature:

1. Find the rubber stopper and label on the side of the lift.



2. Pull the rubber stopper out of the Voyager Portable casing – DO NOT DISCARD.
3. Move the patient over a bed or chair.
4. Using the Allen key provided with this manual, turn the key clockwise to lower the patient into the chair. As the key turns the motor directly, each key turn will move the patient slightly.



To lower the patient more quickly, use a power drill with a 4 mm Allen key bit.



- Once the patient is lowered safely into a chair or bed, take the lift to a certified technician to be serviced.

Battery Information



DO NOT DROP BATTERY. A DROPPED BATTERY MAY HAVE INTERNAL DAMAGE THAT IS NOT VISIBLE. IT MAY LOSE ITS ABILITY TO RECHARGE.

Due to internal damage caused when the battery is dropped, the battery may indicate that it is fully charged, when in fact the battery cannot hold a full charge. A green light indicated on the charger may not accurately reflect a full charge on a damaged battery.

NEVER attempt to use a battery that appears to be damaged or dented.

DO NOT store battery near a heat source. Heat will damage the battery.

Always keep metal battery contacts clean.

- 24 Vdc, 2.0 Ah interchangeable and rechargeable battery.
- Provides 10 to 30 transfers per battery charge (may vary depending on patient weight and battery condition. See graph below).

Life cycle (number of charging cycles) of the battery is largely dependent on the depth of discharge in each cycle. The more the battery is drained, the shorter its life span. The life of the battery is also related to such factors as varying temperatures and rest periods between charge and discharge.

Graph 1: Number of recharge vs. Depth of discharge

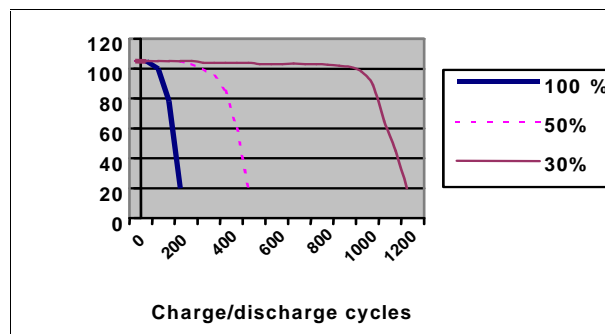

GRAPH #1 illustrates the relationship between discharging depth and expected battery life.

If you use only 30% of the battery power between each charge, you can expect the battery to fully charge 1050 times.

If you drain the battery until it beeps every time, you can expect the battery to fully charge only 300 times.



To prolong battery life - Put the battery into the charger WHENEVER THE LIFT IS NOT IN USE.

The battery will not overcharge.

BHM uses sealed lead-acid batteries. Contrary to nickel-cadmium, BHM batteries do not have any memory effect. Therefore, batteries should not be completely drained before recharge.

Graph 2: Number of lifts vs. Lift load

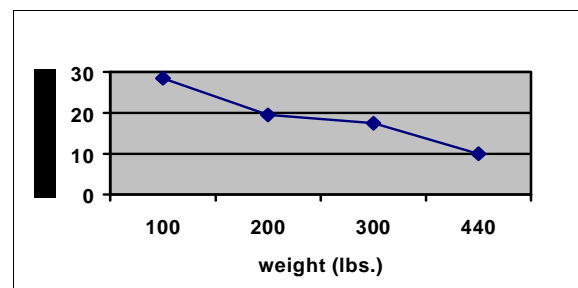

The graph above (GRAPH #2) illustrates the relationship between the load lifted and the number of lifts that can be done with one recharged battery.



Do not drain the battery excessively. This will dramatically reduce the battery life span.

If the low battery buzzer sounds, be sure to recharge the battery as soon as possible.

Charger Specifications #A8200

- Hospital grade charger cord and plug.
- Charger input: 120 Vac, 60 Hz, 0.5 A. (North America)/ 240 Vac, 50 Hz, 0.25 A European.

Charging the Battery with Charger #A8200



DO NOT OPERATE THE CHARGER UNIT WITH A DAMAGED CORD OR IF THE UNIT HAS BEEN DROPPED OR DAMAGED.

DO NOT forcibly bend the power cord or place a heavy object on it. This will damage the cord and may cause fire or electrical shock.

DO NOT pour liquid on or near the charger.



DO NOT place the unit in locations that are:

- Extremely hot
- Dusty or dirty
- Very humid
- Moving or vibrating

Do not attempt to put a damaged battery into a charger. Inspect the battery first for dents or damage.

The recharging steps should be as follows:

(See step by step instructions)

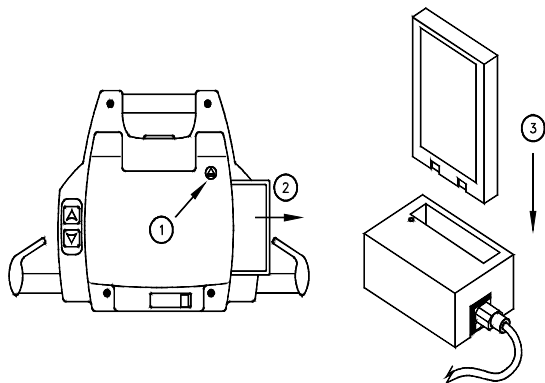

- Eject the battery from the lift unit by using the "Battery Eject Button" (1). Keep your hand near the opening to catch the battery (2).



Keep one hand near the opening for the battery (2) before pushing eject button. Do not allow the battery to eject and fall.

- Insert the battery into the charger (3) with the silver contact points of the battery going into the charger.
- The charging indicator light will illuminate red to white to green depending on the battery drain. If the light does not go on, check the "Troubleshooting" section in this manual for assistance.
- If the battery is low, the light will show red or orange when you place the battery in the charger. The light will gradually turn to a white or yellow colour, then to green when fully charged.



Whenever possible, leave the battery in the charger when the lift is not in use.



- When the lift is needed again, pull the battery out of the charger, and gently slide it back into the Voyager Portable lift. The silver contacts should be inside the lift.
- The power cord can remain plugged into the wall indefinitely, convenient for overnight recharging.
- If the battery has been in the charger for an extended period of time or if the battery has not been drained: it is possible that the light on the charger will turn off, or will not go on. This is only the case when the battery is 99.9% charged.
- To test the charger, use the battery in the lift a few times then put the battery in the charger. If the light still does not go on, see the "Troubleshooting" section.

Charger Specifications #700.13500



- Class 2 power cord rated at 2.5 A (100-240 Vac 50-60 Hz).
- Charger input: 100-240 Vac, 50-60 Hz, 50VA
- Charger output 27 Vdc 1A.
- Input fuse – 1A 250 V located inside the charger.

Green light showing power to the charger
 Solid yellow light showing battery 85% charge
 Yellow light blinking showing battery under charge

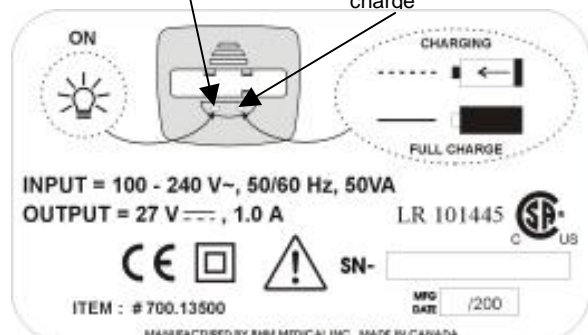

Charging the Battery with Charger # 700.13500

(Available Oct. 2001)

Check to make sure the green light on the charger is illuminated. This indicates that the charger is on.

- Insert the battery into the charger with the silver contact points of the battery going into the charger.
- The charging indicator light will flash yellow while the battery is charging. If the battery is approximately within 85% of being fully charged, the charging indicator light will illuminate solid yellow.
- If the battery is low, it will take approximately 2 hours for a full charge.



Whenever possible, leave the battery in the charger when the lift is not in use.

At minimum, charge the battery until the light is solid yellow (not flashing) before using again. This will extend the life of the battery.

- When the lift is needed again, pull the battery out of the charger and, gently slide it back into the Voyager Portable lift. The silver contacts should be inside the lift.
- The power cord can remain plugged into the wall indefinitely, convenient for overnight recharging.
- The battery can be left in the charger for an extended period of time without damaging either the charger or battery.
- If the green light does not go on when the charger is plugged into an electrical outlet, see "Troubleshooting" section.

MAINTENANCE



ALWAYS CARRY OUT THE DAILY CHECKLIST BEFORE EACH LIFT USE.

DO NOT attempt to open the VOYAGER PORTABLE. Only a certified technician is authorized to open the VOYAGER PORTABLE.

Alterations made to the VOYAGER PORTABLE by someone other than a certified technician may cause serious injury.

VOYAGER PORTABLE and accessories must

be inspected ANNUALLY by a certified technician in addition to the daily and other periodic visual checks done by the user specified in this section.

Preventive maintenance specified in this manual can prevent accidents and reduce repair costs.

Daily Check List

THE FOLLOWING PROCEDURE MUST BE FOLLOWED BEFORE EACH USE.

- Has the battery been charged? Charge the battery whenever the lift is not in use.
- Inspect the battery before placing it in the Voyager portable. If the battery appears to have any damage – DO NOT USE IT. Replace the battery immediately (Product # A8500).
- Inspect the lift for any damage. If the lift casing does not look properly aligned, or there are any cracks or other damage on the lift, or any parts are missing - DO NOT USE IT. Contact your local representative to have the lift serviced.
- Attach the lift to the trolley in the rail. Inspect the visible strap for any signs of wear, frays, loose threads or other damage. If there is any evidence of damage- DO NOT USE IT. Contact your local representative to have the lift serviced.
- Inspect the sling for tear, frayed straps or loose stitching. If the sling has any of the above damage –DO NOT USE IT. Contact your local representative to have the sling replaced or repaired.
- Inspect the arm extension and the adjustable extension strap (if you have these options) for wear. Check the adjustable extension strap for frays or loose stitching. Check the arm extension for damage in the metal hook or handle. DO NOT USE if there is any damage.
- Inspect the hook at the top of the strap to ensure it is properly attached and there is no damage to the hook.

Inspection and Cleaning

Clean the VOYAGER body with a dry soft cloth, or a soft cloth lightly moistened with a mild detergent solution. Do not use any type of solvent that may damage the finish.



To ensure a better rolling surface for the trolley wheels, clean the inside of the track every 4 months. To do so, insert a damp cloth in the opening and slide it from one end of the track to the other.

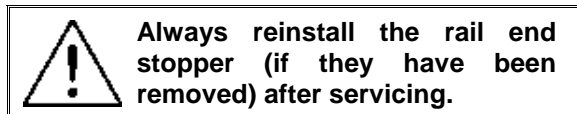

Strap Inspection

This equipment is built with a strap that can withstand a load of 1364 kg (3000 lbs.) Nonetheless, if this strap is damaged or shows signs of wear the acceptable load on the strap before rupture can drop rapidly and present a danger for the patient or caregiver.

BHM Medical recommends thoroughly inspecting the strap every 2 months as follows:

1. Completely unwind the strap.
2. Look for any signs of wear.

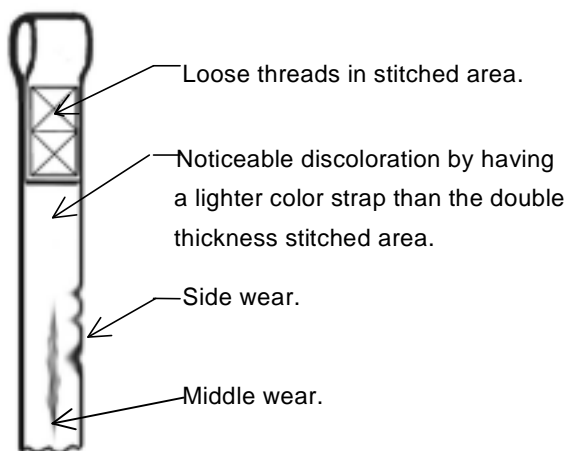

If there are any signs of wear as indicated here or other visual defects, strap should be changed immediately. By continuing to use the lift without changing the strap, caregiver and patient safety is greatly compromised.

In any case, the manufacturer recommends to change the strap at least every two years. By continuing to use the lift without changing the strap, caregiver and patient safety is greatly compromised.

Handling and Storage

Avoid violent shock during transportation.

The lift should not remain stored for long periods of time without recharging the batteries.



BHM Medical recommends charging of batteries at least every two weeks even if the lift is not used. This will prevent premature aging of batteries.

Battery Replacement

BHM uses sealed lead-acid batteries. Contrary to nickel-cadmium, BHM batteries do not have any memory effect. Therefore, batteries should not be completely drained before recharge.

Replace the battery when it has been dropped or if there is a noticeable reduction in the number of transfers that can be performed between charges. If you notice the Voyager Portable "beeping" – see the instructions in "Troubleshooting" section to ensure it is a problem with the battery.

To replace a battery, contact your local dealer or representative and order product # A8500.



DO NOT ATTEMPT TO USE A BATTERY NOT AUTHORIZED BY BHM MEDICAL.

BHM batteries are specially designed for BHM charging systems. Attempting to use an unauthorized battery may seriously damage the lift and/or the charger.

Charger Fuse Replacement

(Charger #A8200 only)

If the charger light does not illuminate when there is a battery in it, do the following steps:

1. Make sure the battery is properly placed in the charger. The silver contact points should be inside the charger.
2. Check to make sure the power cord is correctly plugged into the charger and the wall.
3. If the light still does not work, plug the charger into a different outlet in a different area to ensure that the outlet is working properly.
4. Pull the power cord out of the charger. Under the socket on the charger, there is a drawer or magazine where there is a fuse. Using a pen or screwdriver, pull the drawer out gently. Pull the burnt fuse out of the drawer that is next to the charger (see diagram below) and discard. Take the replacement fuse and place it in the same slot where the burnt fuse was. Slide the drawer back into the charger. Plug the power cord into the charger. Place the battery into the charger and check for the light.
5. If the light does not illuminate, contact your local dealer or representative for assistance.

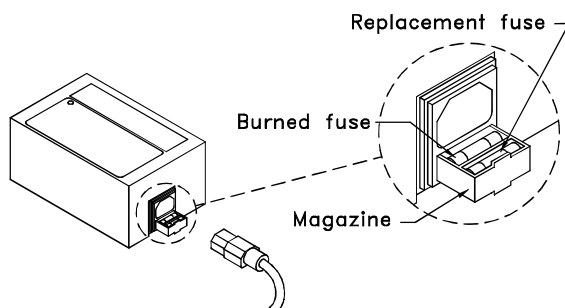

Replace the fuse with the following:

Fuse: GMC 0.5 A 250 V North America (When input is 120 Vac) Product # C8FGMC0.5

GMC 0.25 A 250 V European (When input is 240 Vac) Product # C8FGMC0.250

The fuse may also be ordered through your local dealer or representative.

Annual Inspection

The Voyager Portable and its accessories must be inspected annually by a certified technician.



VOYAGER PORTABLE AND ACCESSORIES MUST BE SERVICED EVERY 12 MONTHS AS A MINIMUM REQUIREMENT.

Do not attempt to do the inspection unless you are certified to do so.

As part of the annual inspection, an annual load test with the safe working load must be performed on the VOYAGER PORTABLE as required for CE MARK MAINTENANCE.

Strap replacement

1. Stand up the VOYAGER on a solid table. Remove the hook. Remove the strap guide by unscrewing the 2 screws.



2. Put the VOYAGER on the back and unscrew the 2 screws on the carry handle and the 2 screws at the bottom of the device.



3. Flip the VOYAGER and put it on his front. Unscrew the *Quick Release* button, the 4 screws on the cab and the 2 screws on the carry handle.



Gently, remove the rear cab from the Voyager. Just lift enough the frame from the front cab to unplug the 2 control switch connectors from the circuit board. Stand up the frame on a solid surface. Be careful with the circuit board under the frame.



4. Temporarily screw the *Quick Release* knob and with one hand activate the *Quick Release* and with the other pull out the entire strap from the drum.



Look at the two holes on the frame (battery side) and align the two bolts of the drum by turning the drum.

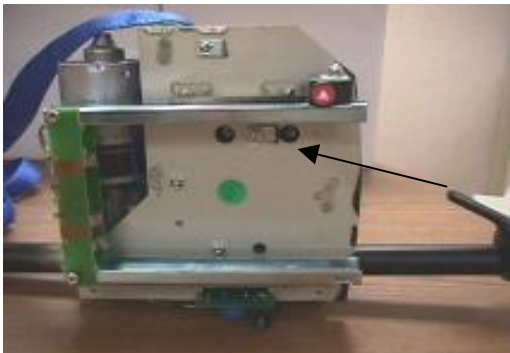

5. Unscrew the long bolt from the drum.



Activate the *Quick Release* and pull the strap just enough to make half turn to the drum and align the other screw with the first hole of the frame. Be sure the *Quick Release* is in correctly. Unscrew the drum bolt and remove the strap.

6. Install the strap in the drum (loop outside) and screw the first bolt through the strap to the drum.



Make half turn to the drum and screw the other bolt to the drum.

Insert the other end of strap through the limit switch hole. With one hand insert the end of strap and with the other hand one finger push the limit switch and another finger guide the strap through the hole.



Pull out the entire strap from the frame. Hold the end of strap, activate the *Quick Release* and let the entire strap roll on the drum.

7. Unscrew the *Quick Release* button. Gently put the frame in the front cab just enough to

plug the 2 control switches like **step 3**. Place the carry handle in the front cab. Place the rear cab and screw a few thread of all 6 screws front the rear cab. Tighten the *Quick Release* button.

8. Flip the Voyager. Unscrew a few threads of all the 4 screws from the front cab. Install the strap guide and screw it. Align the cab and tight the 4 carry handle screws. Tighten the 2 centre screws from the rear cab.



9. Flip the Voyager to the front. Screw the 2 screws at the bottom of the cab. Verify the eject battery button for working properly.



10. Stand up the Voyager. Pull on the strap and verify the *Quick Release* for proper operation.
11. Tighten both screws one after the other while checking the *Quick Release* to make sure it is not stuck. If stuck, unscrew a little until *Quick Release* is functional.

Drum Replacement

1. Do step 1 to 3 from the **strap replacement** instructions.
2. Rewind the entire strap on the drum and fix it with tape. Temporarily screw the *Quick Release* knob. Activate the *Quick Release* with one hand and with the other slow the drum to permit to remove the 4 turns of pre-load until you place in front of you the spring screw.



3. Unscrew the spring screw just enough to loosen the spring. With pliers, grab the spring and locate it on the frame wall like showed.



4. Remove the circlip on the centre shaft of drum and pull out the shaft through the frame.



5. Pull out the drum from the frame. BE careful not to loose any pieces.



6. Unscrew the spring screw on the old drum and fix it to the new drum just a few thread. Install the new drum. Hold the washer and spring to the drum with a screwdriver or home knife and insert the drum in the frame. You may have to push on the "Quick Release" button.



7. Reinstall the centre shaft through the frame and lock with the circlip. With pliers grab the spring and locate it on the screw to the frame. Tighten the spring screw.
8. Activate the *Quick Release* button with one hand and with the other turn the drum to permit to put the 4 turns of pre-load until you place in front of you the strap end and pass the strap through the limit switch hole.
9. Unscrew the Quick Release button. Gently put the frame in the front cab just enough to plug the 2 control switches like **step 3**.
10. Place the carry handle in the front cab. Place the rear cab and screw a few threads of all 6 screws on the front and rear cab. Tighten the *Quick Release* button.
11. Flip the Voyager. Unscrew a few threads of all the 4 screws from the front cab. Install the strap guide and screw it. Align the cab and tight the 4 carry handle screws. Tighten the 2 centre screws from the rear cab.



12. Flip the voyager to the front. Screw the 2 screw at the bottom of the cab. Verify the eject battery button for working properly.



Limit Switch Replacement

1. Stand up the Voyager on a solid table. Remove the Hook and remove the strap guide by unscrewing the 2 screws.



2. Put the Voyager on the back and unscrew the 2 screws on the carry handle and the 2 screws at the bottom of the device.



3. Flip the Voyager and unscrew the *Quick Release* button, the 4 screws on the cab and the 2 screws on the carry handle.
4. Stand up the Voyager. Pull on the strap and verify the *Quick Release* for proper operation.
5. Tighten both screws one after the other while checking the *Quick Release* to make sure it is not stuck. If stuck, unscrew a little until *Quick Release* is functional.



6. Gently, remove the rear cab from the Voyager. Just lift enough the frame from the front cab to unplug the 2 control switches connector from the circuit board. Stand up the frame on a solid surface. Be careful with the circuit board under the frame



7. Unscrew the 2 screws on the limit switch with a flat tip screwdriver and the appropriate key.



8. Unplug the 2 blue wires from the limit switch.



9. Replace the limit switch by a new one and plug back the 2 blue wires on both end of the limit switch.
10. Screw back in the 2 screws on the limit switch.



11. Gently put the frame in the front cab just enough to plug back the 2 control switches to the board. Place the carry handle in the front cab. Place the rear cab and screw a few thread of all 6 screws front the rear cab. Tighten the *Quick Release* button.
12. Flip the Voyager and unscrew a few thread of all the 4 screws from the front cab. Install the strap guide and screw it. Align the cab and tight the 4 carry handle screws. Tighten the 2 center screws from the rear cab.

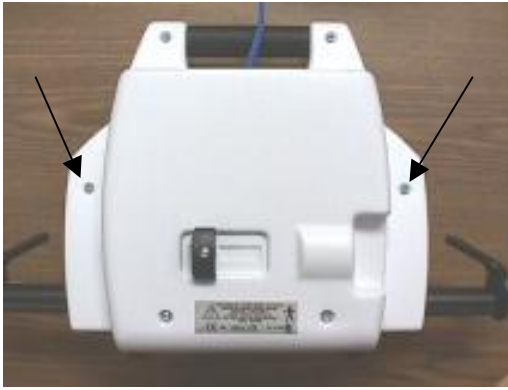

13. Flip the Voyager to the front. Screw the 2 screws at the bottom of the cab. Make sure the eject battery button is working properly.



14. Stand up the Voyager. Pull on the strap and verify the Quick Release for proper operation.
15. Tighten the two screws under the *Quick Release* while checking if the *Quick Release* is moving freely. If stuck, unscrew a little until the *Quick Release* is functional.

Limit Switch Rod Replacement

1. Do steps 1 to 7 from the limit switch replacement instructions.
2. Remove the spring from the limit switch rod.



3. Drill out the rivet from the other side and remove the limit switch rod.

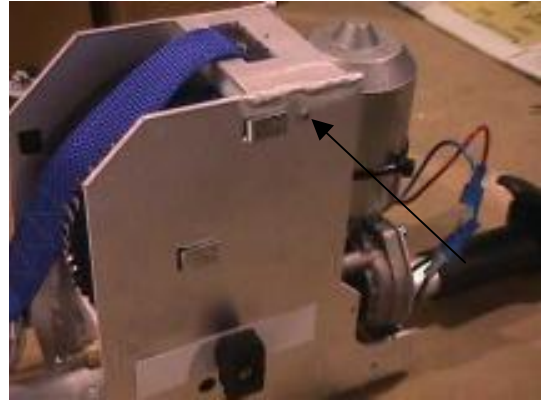

4. Insert the new rod. Insert the rivet in the rod hole and pop up the rivet.



5. Put the spring back on the limit switch rod.
6. Do steps 11 to 15 of the limit switch replacement instructions.

Bloc SSRS Replacement

1. Stand up the Voyager on a solid table. Remove the hook and remove the strap guide by unscrewing the 2 screws.



2. Put the Voyager on the back and unscrew the 2 screws on the carry handle and the 2 screws at the bottom of the device.



3. Flip the Voyager and unscrew the *Quick Release* button, the 4 screws on the cab and the 2 screws on the carry handle.



4. Gently, remove the rear cab from the Voyager. Just lift enough the frame from the front cab to unplug the 2 control switch connectors from the circuit board. Stand up the frame on a solid surface. Be careful with the circuit board under the frame.

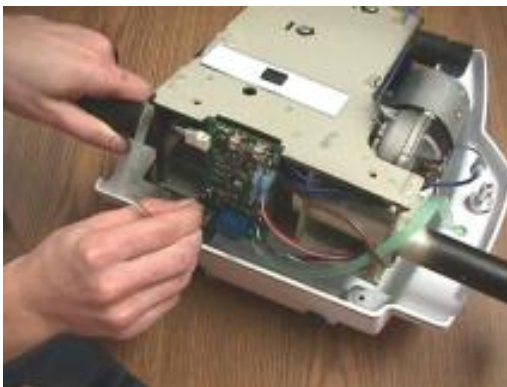

5. Unscrew the "No 20 Torx screw". The electric board does not need to be unplugged. It only needs to be removed from the frame so the SSRS bloc can be reach.

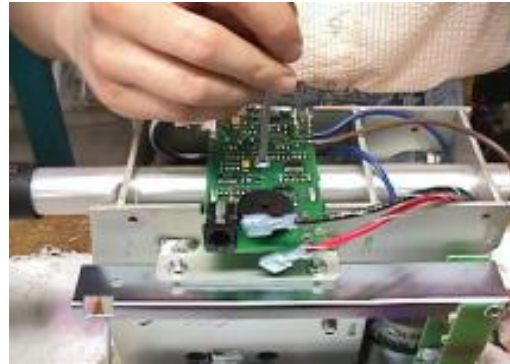

6. Unplug the blue and white wires plug.



7. Unscrew the two small limit switch bolts and remove the limit switch's board.



8. The next step would be to remove the drum. First, rewind the entire strap on the drum and fix it with tape. Temporarily screw the *Quick Release* knob. Activate the *Quick Release* with one hand and with the other slow the drum to permit to remove the 4 turns of pre-load until you place in front of you the spring screw.



9. Unscrew the spring screw just enough to loosen the spring. With a pliers, grab the spring and locate it on the frame wall like showed.



10. Remove the circlip on the center shaft of drum and pull out the shaft through the frame

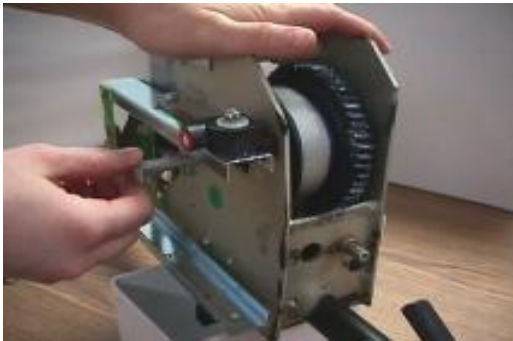

11. Pull out the drum from the frame. Be careful not to loose any pieces.



12. Once the drum is removed, the next step is to pull out the electric motor. First, unplug the two wires attached to the motor.



13. Unscrew the 3 motor bolts and pull it out from the frame. When you pull out the motor, make sure the shaft stay assembled with the motor. The bearing does not need to stay with the shaft.

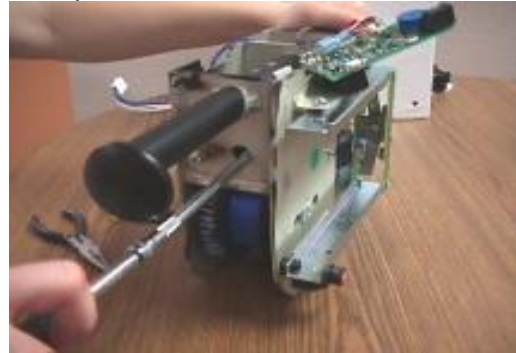

14. Uncouple the spring (1) that holds the CBLM plate (2) and unclip the SSRS bloc (3) from the CBLM plate (2). To unclip it, while holding the CBLM plate, push the block out.

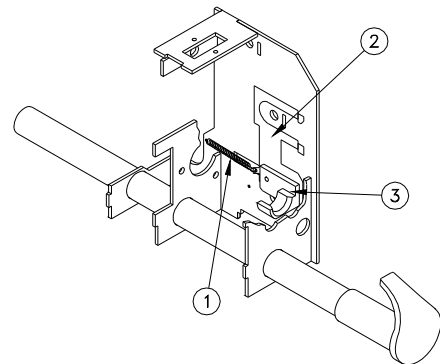

15. Replace the SSRS block and clip the new block in the slot of the CBLM plate. To clip

the block, make sure to push the plate in the bottom of the SSRS block slot.



16. Put the bearing, shaft and motor in place. The bearing has to be placed between the brass bushing and the shaft with the writing on the bearing against the frame.

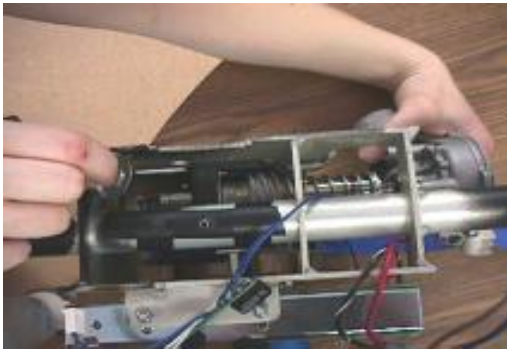

17. Reinstall the drum. Hold the washer and spring to the drum with a screwdriver or home knife and insert the drum in the frame. You may have to push on the "Quick Release" button.



18. Reinstall the center shaft trough the frame and lock it with the circlip. With pliers, grab the spring and locate it on the screw of the drum. Tighten the spring screw.



19. Activate the *Quick Release* button with one hand and with the other, turn the drum to permit to put the 4 turns of pre-load on the spring. Place the strap end in front of you, take out the tape and pass the strap through the limit switch hole.



Make sure the strap goes through the limit switch hole after being guided by the white roller as shown on the drawing. If not, change the direction of rotation.

20. Screw back in the two limit switch boards. Once it is done, verify that when sliding the Quick Release, it activated ("click") the two limit switches.

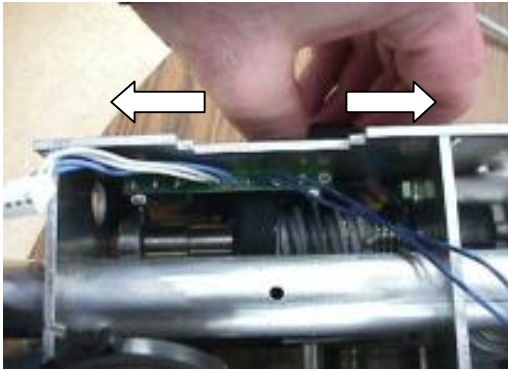

21. Screw the electric board back in place and plug the unplugged wire to it. Plug the brown wire in the red motor plug and the blue and purple wire together.
22. Gently put the frame in the front cab just enough to plug back the 2 control button connectors with the white dot mark facing the Quick Release (back) side. Place the carry handle in the front cab. Place the rear cab and screw a few thread of all 6 screws front the rear cab. Tighten the *Quick Release* button.
23. Flip the Voyager and unscrew a few thread of all the 4 screws from the front cab. Install the strap guide and screw it. Align the cab and tight the 4 carry handle screws. Tighten the 2 center screws from the rear cab.



24. Flip the Voyager to the front. Screw the 2 screws at the bottom of the cab. Make sure the eject battery button is working properly.



25. Stand up the Voyager. Pull on the strap and verify the Quick Release for proper operation.
26. Tighten the two screws under the Quick Release while checking if the Quick Release is moving freely. If stuck, unscrew a little until the Quick Release is functional.

Mica Replacement

1. Stand up the Voyager on a solid table. Remove the hook and remove the strap guide by unscrewing the 2 screws.



2. Flip the Voyager and put it on his front. Unscrew the *Quick Release* button, the 4 screws on the cab and the 2 screws on the carry handle.



2. Gently, remove the rear cab from the Voyager. Replace the mica by the new one.



3. Place the rear cab and screw a few thread of all the 6 rear cab screws. Tight the *Quick Release* button.

4. Flip the Voyager and unscrew a few thread of all the 4 screws from the front cab. Install the strap guide and screw it. Align the cab and tighten the 4 carry handle screws. Tighten the 2 centre screws from the rear cab.



6. Make sure the eject battery button is working properly.
7. Stand up the Voyager, pull the strap and verify the Quick Release for proper operation.
8. Tighten the two (2) screws under the Quick Release one after the other while checking if the *Quick Release* moves freely. If stuck, unscrew a little until *Quick Release* is functional.

Circuit Board Replacement

1. Stand up the Voyager on a solid table. Remove the hook and remove the strap guide by unscrewing the 2 screws.



2. Put the Voyager on the back and unscrew the 2 screws on the carry handle and the 2 screws at the bottom of the device.



3. Flip the Voyager and unscrew the *Quick Release* button, the 4 screws on the cab and the 2 screws on the carry handle.



4. Gently, remove the rear cab from the Voyager. Just lift enough the frame from the front cab to unplug the 2 control switch connectors from the circuit board. Remove the frame from the front cab.



5. Unplug the red/white and the black/white wires from the board.



6. Unplug the blue and white wires plug.



7. Unplug the two wires (brown and blue) attached to the motor.

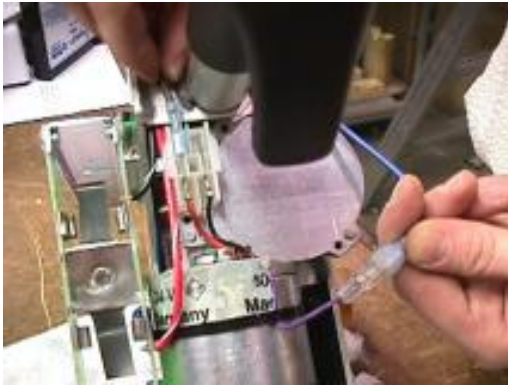

8. Unscrew the “No 20 Tork screw”. To remove the electric board.

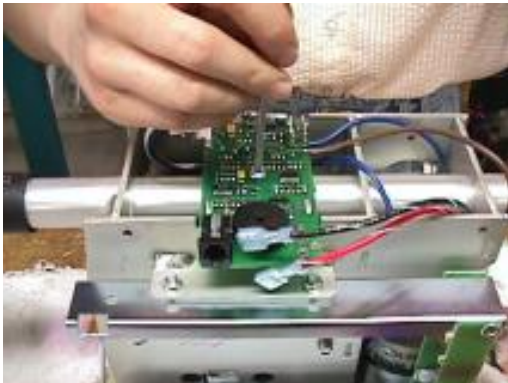

9. Screw the new electric board back in place and plug the unplugged wire to it. Plug the brown wire in the red motor plug and the blue and purple wire together.
10. Gently put the frame in the front cab just enough to plug back the 2 control button connectors with the white dot mark facing the Quick Release (back) side. Place the carry handle in the front cab. Place the rear cab and screw a few threads of all 6 screws front the rear cab. Tighten the *Quick Release* button.
11. Flip the voyager and unscrew a few threads of all the 4 screws from the front cab. Install the strap guide and screw it. Align the cab and tighten the 4 carry handle screws. Tighten the 2 centre screws from the rear cab.



12. Flip the Voyager to the front. Screw the 2 screws at the bottom of the cab. Make sure the eject battery button is working properly.



13. Stand up the Voyager pull on the strap and verify the *Quick Release* for proper operation.
14. Tighten the two screws under the *Quick Release* while checking if the *Quick Release* is moving freely. If stuck, unscrew a little until the *Quick Release* is functional.

Touch Pad Membrane replacement

1. Put the Voyager on the back and unscrew the 2 screws on the carry handle and the 2 screws at the bottom of the device.



2. Flip the Voyager and unscrew the 2 centre screws from the rear cab.



3. Flip the Voyager and gently, remove the front cab from the Voyager. Just lift enough

MAINTENANCE

the frame from the front cab to unplug the 2 control switch connectors from the circuit board. Be careful with the circuit board under the frame.



4. Remove the old membrane with a thin blade. If necessary, remove traces of adhesive with a mild solvent.



If the new membrane does not have a white dot on the connector, turn the membrane over and on the back put a white point on the right side of the connector.



5. Replace the new one by passing the cable into the cab hole. Peel the backing off the membrane and stick it to inside of the cab.



6. Gently put the frame in the front cab just enough to plug back the 2 control button connectors with the white dot mark facing the Quick Release (back) side. Place the carry handle in the front cab. Replace the rear cab and screw a few threads of all 6 screws front the rear cab. Tighten the *Quick Release* button.

7. Flip the voyager Unscrew a few threads of all the 4 screws from the front cab. Install the strap guide and screw it. Align the cab and tighten the 4 carry handle screws. Tighten the 2 centre screws from the rear cab.



8. Flip the Voyager to the front. Screw the 2 screws at the bottom of the cab. Verify the eject battery button is working properly.



9. Stand up the Voyager pull on the strap and verify the Quick Release for proper operation while checking the *Quick Release* to make sure it is not stuck. If stuck, unscrew a little until *Quick Release* is functional if necessary.

MAINTENANCE INSPECTION CHECKLIST

Maintenance Inspection Checklist

ITEM	TO BE INSPECTED BY A CERTIFIED TECHNICIAN = X					
	INITIALLY	BEFORE EVERY USE	EVERY 2 MONTHS	EVERY 6 MONTHS	EVERY YEAR	EVERY 2 YEARS
LIFT DEVICE						
Inspect for missing hardware or broken panel.	X	O		X		
Inspect strap for wear.			O			
Recharging battery.		O				
Inspect round hook on the strap of the lift for damage or cracks.				X		
Inspect trolley in rail for damage, rust or cracks. Replace if damaged.				X		
Overall inspection by authorized personnel				X		
SLING AND HARDWARE						
Check all sling attachments for sign of wear.		O				
Inspect sling material for wear or deterioration.		O				
Inspect sling straps for wear.		O				
Inspect for any defect or loose threads in the "stitched areas".		O				
Cleaning sling as indicated on the tag.	<i>When Necessary</i>					
ACCESSORIES						
Verify strap extension for wear				X		
Verify arm extension for wear				X		





MAINTENANCE BY A CERTIFIED TECHNICIAN						
Replace strap.						X
Inspect the welding on the frame to detect cracks.					X	
Inspect connecting joints for proper attachment.					X	
Verify that the emergency brake on the drum is turning freely.				X		
Verify emergency devices for good functioning.				X		

	<p>Maintenance inspection points are suggested by the manufacturer, however in certain cases, some inspections should be done on a more frequent basis. By continuing to use the lift without replacing the listed parts in this maintenance inspection checklist, caregiver and patient safety is greatly compromised.</p>
---	---

TROUBLESHOOTING



DO NOT attempt to open the VOYAGER PORTABLE. Only a certified technician is authorized to open the VOYAGER PORTABLE. Alterations made to the VOYAGER PORTABLE by someone other than a certified technician may cause serious injury.

PROBLEMS	TO CHECK
The unit does not work when you press the  or  buttons on the handset.	<ul style="list-style-type: none"> • Make sure the handset is plugged correctly into the unit. • Use the control switches directly on the unit. If they are working, it indicates a problem with the handset; you would then need to change the handset.
The unit does not work when you press the  or  buttons on both sides of the lift.	<ul style="list-style-type: none"> • Is the battery charged and correctly installed? Ensure the battery is inserted into the lift with the silver contact points inside the lift. Place the battery into the charger and check the light on the charger. If the light remains red, leave the battery in the charger for approximately 2 hours. • Is the “QUICK RELEASE” knob completely to the left (locked) position? If not, the lift will not operate. Tighten the tension on the strap to help move the “Quick Release” knob. • Is there tension on the strap? The “Anti Crush” feature will prevent the lift from working if there is no tension. • If all of the previous points have been checked without success, you probably have a motor or electric problem, you then need to call your BHM Medical representative.
The unit starts and stops repetitively.	<ul style="list-style-type: none"> • If the load is more than safe working load, the unit will not work due to an overload protection on the motor. • Has the lift been making a “beeping” sound? The battery is low and needs to be charged.
The lift emits a “beep” during utilization. The unit may stop lifting but you can still lower it.	<ul style="list-style-type: none"> • Batteries are low, recharge them.
Charge indicator on the charger #A8200 (green-red) does not light up when the battery is in the charger	<ul style="list-style-type: none"> • Check the orientation of the battery. The silver contact points should be inside the charger. • Is the charger plugged into a standard outlet? • Check the condition of the fuse. If needed, change it with a spare one. (see “Maintenance” section of this manual) • Has the battery been in the charger for many hours? See “Battery Information” and “Charging the Battery “ in “Maintenance” section.
The light on the charger #A8200 shows green when the battery is inserted; yet the lift will only work when there is no one in the lift. When you attempt to transfer someone, the lift stops.	<ul style="list-style-type: none"> • Battery is damaged – have it replaced.
The light on the charger #A8200 always lights up red – does not turn to green after an overnight charge.	<ul style="list-style-type: none"> • Try a different battery in the charger if available. • Take the battery and charger to a certified technician.

TROUBLESHOOTING

PROBLEMS	TO CHECK
Battery is always dead after a few transfers (3 to 5).	<ul style="list-style-type: none"> • Replace battery with a new one, the life of the current one is probably nearly over. (See the "Battery Information" section on page 10)
The light on the charger shows green (yellow for charger #700.13500) when the battery is inserted, yet the lift will only do one or two transfers.	<ul style="list-style-type: none"> • Battery has either been dropped or damaged in some other way. Replace the battery.
Charger #700.13500: Green light is not illuminated	<ul style="list-style-type: none"> • Is the charger plugged into a standard outlet? • Try plugging the charger into another outlet to see if it will work. • Contact your local dealer or representative.
Charger #700.13500: When battery is inserted into the charger, the yellow light does not flash or illuminate solid.	<ul style="list-style-type: none"> • Check the orientation of the battery. The silver contact points should be inside the charger. • Contact your local dealer or representative.
The battery does not slide into the lift.	<ul style="list-style-type: none"> • Check if there is any damage to the battery that would interfere in the lift battery's slot. IF THERE IS DAMAGE - DO NOT USE THE BATTERY. • Try to slide in another battery to see if there is any damage in the lift battery's slot. If so, call your BHM Medical representative, if not discard the damaged battery.
Cannot remove battery from the lift.	<ul style="list-style-type: none"> • See "Operation" instructions "Charging the Battery" on how to remove the battery. • If the battery will not come out of the lift, tilt the lift to the side so that the battery opening is under the lift. With your hand guarding the opening for the battery, press the eject button on the front of the Voyager Portable while gently tapping the lift to help jolt the battery out of the lift. ONCE THE BATTERY IS REMOVED – DISCARD BATTERY AND REPLACE. • If you cannot remove the battery after trying the above, contact your local dealer or representative for assistance.

ACCESSORIES

BATTERY

Product No. A8500

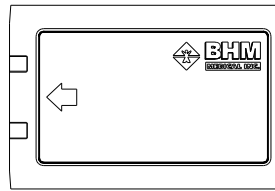

HOOK

Product No. Q8000

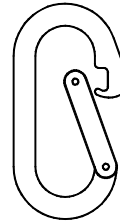

CHARGERS

Product No. A8200

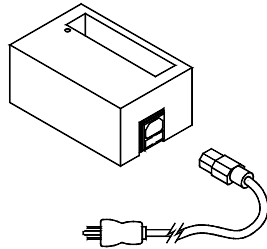

STANDARD TROLLEY

Product No. A5900

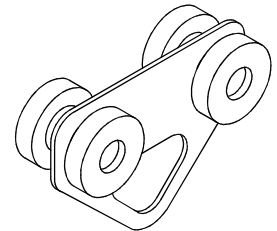

Product No 700.13500

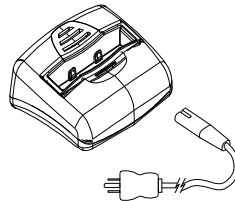

SWIVEL TROLLEY

Product No. A5910

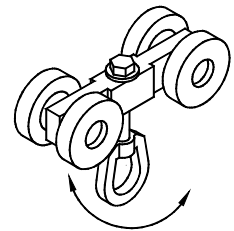

**HOSPITAL GRADE
POWER CORD**

Product No. E7525 North America
E7521 Europe
E7527 UK
E7528 Australia

ARM EXTENSION

Product No. A8300

FUSE

Product No.
C8FGMC0.5 (120/24 volt) North America
C8FGMC0.25 (240/24 volt) European

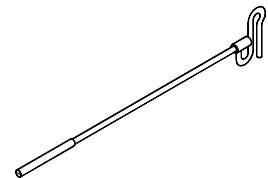
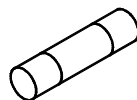

HANDSET

Product No. 700.13600

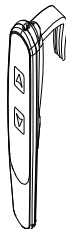

ADJUSTABLE STRAP EXTENSION

Product No. A3710

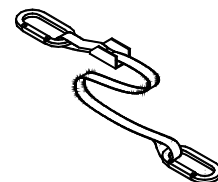

PARTS LIST

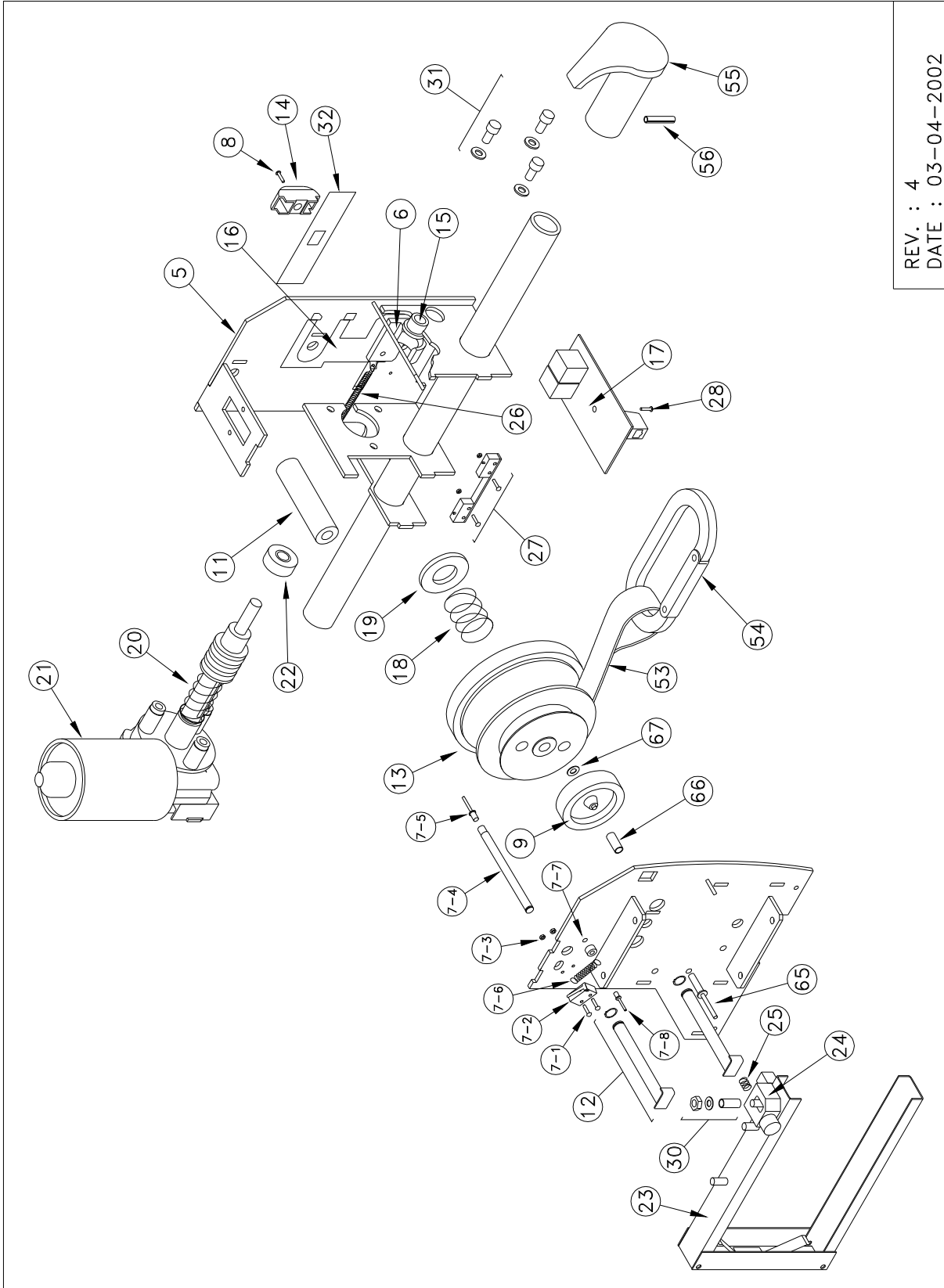

REV. : 4
DATE : 03-04-2002

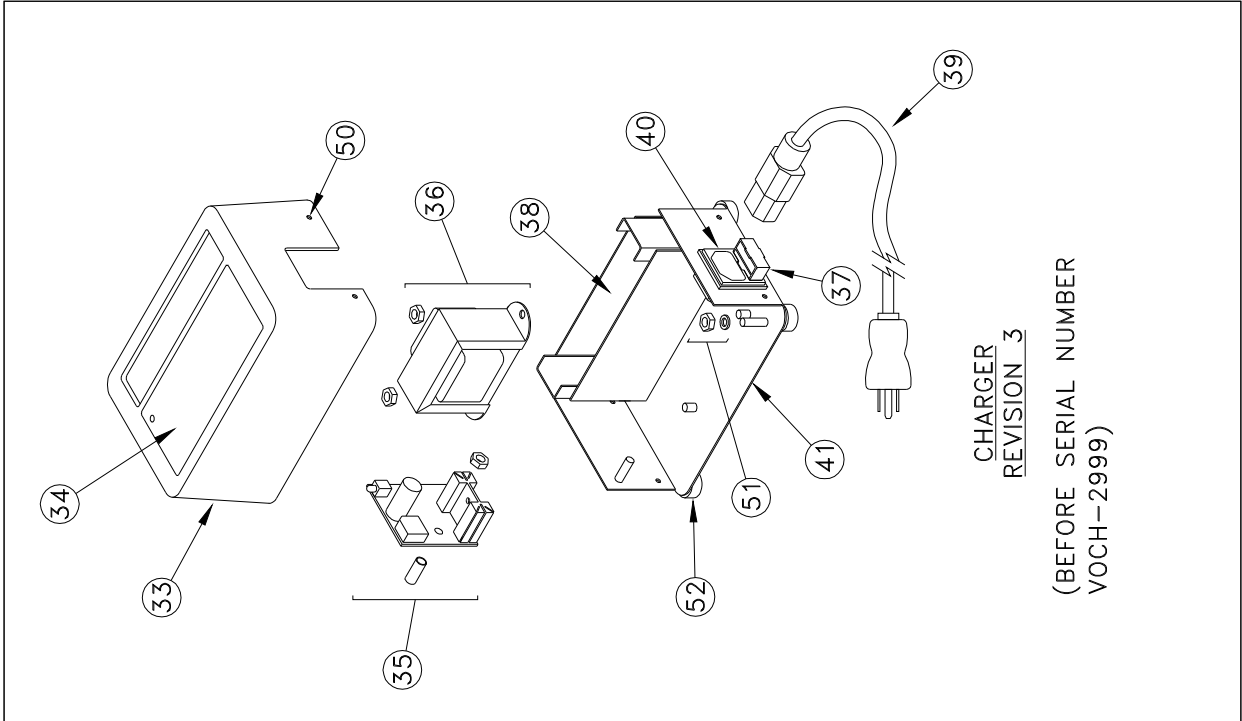

CHARGER
 REVISION 3
 (BEFORE SERIAL NUMBER
 VOCH-2999)

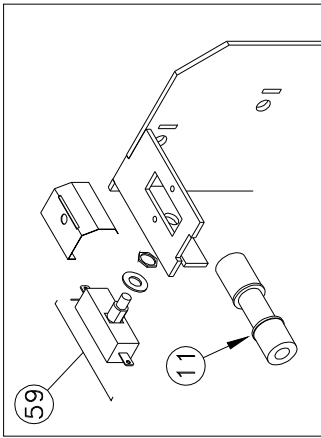

LIMIT SWITCH SYSTEM
 REVISION 2
 -ITEM 11, STRAP GUIDE
 ROLL #M8520 (REV. 9)
 (BEFORE SERIAL NUMBER
 VOYA-1709)

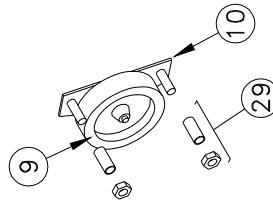

(BEFORE SERIAL NUMBER
 VOYA-3719)

PARTS LIST

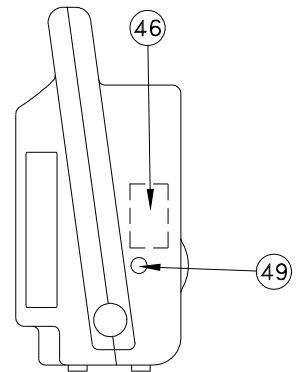
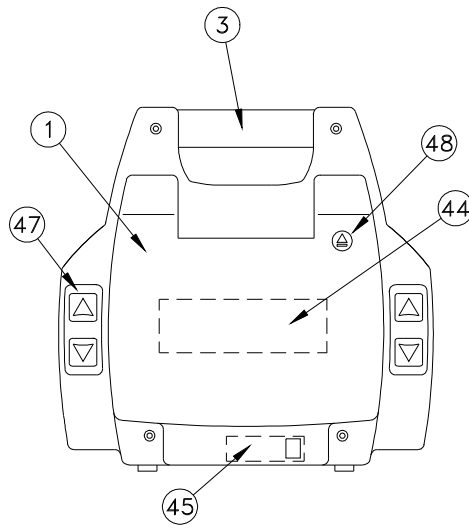
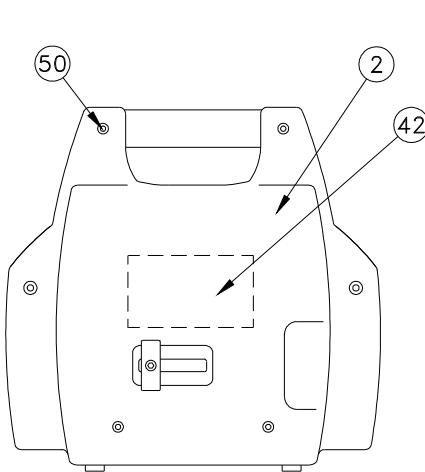
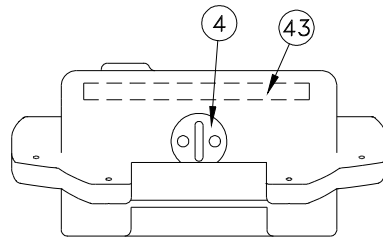
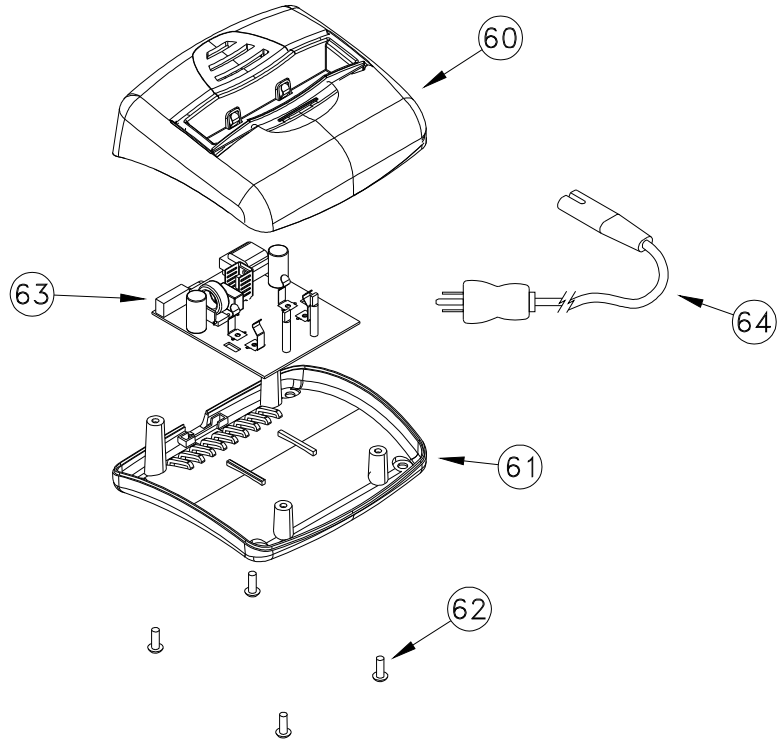

PART LIST

<u>ITEM NO.</u>	<u>QTY.</u>	<u>PART NO.</u>	<u>DESCRIPTION</u>
1	1	A8175	VOYAGER FRONT CAB ASSEMBLY
2	1	A8180	VOYAGER BACK CAB ASSEMBLY
3	2	M8095	CARRY HANDLE (1/2)
4	1	M8071	STRAP GUIDE
5	1	M8000	VOYAGER ALUMINIUM FRAME
6	1	M8081U	SSRS PUSH BLOCK
7-1	2	000.00005	SCREW 2-56 X 5/8"
7-2	1	460.00005	SWITCH-STOP LIMIT
7-3	2	000.00022	LOCKNUT# 2-56
7-4	1	200.08120	LIMIT SHAFT
7-5	1	000.00887	POP RIVET 1/8 X 3/8
7-6	1	000.00873	6.5 X 25mm SPRING
7-7	1	000.02535	5 X 5mm NYLON SPACER
7-8	1	000.00897	RIVET 3/16 x 1/4-3/8
8	1	000.00640	TAP SCREW M4.8 x 19mm TORX
9	1	000.00882	SPIRAL REWIND SPRING
10	1	M8030	SPRING SUPPORT
11	1	M8520	STRAP GUIDE ROLL
12-1	2	M8065	9mm STEEL SHAFT
12-2	2	000.00846	SNAP RING 9mm
13	1	A8051	DRUM ASSEMBLY WITH STRAP (COMPLETE)
14	1	M8086	SSRS KNOB
15	1	000.01048	BRASS FLANGE BUSHING
16	1	M8035	CBLM PLATE
17	1	E8010	BHM-20 CIRCUIT BOARD
18	1	M8047Z	CBLM WASHER SPRING
19	1	M8046	CBLM WASHER
20	1	A8020-VOYA	DRIVE SHAFT ASSEMBLY
21	1	E0006	ELVI MOTOR
22	1	000.01083	THRUST BEARING 3/8"
23	1	A8040	BATTERY CONTACT ASSEMBLY
24	1	M8101	EJECT BATTERY BUTTON
25	1	000.00872	EJECT BUTTON SPRING
26	1	000.00873	6.5 x 25mm SPRING
27-1	1	A8030	LIMIT SWITCH ASSY (INCLUDE ITEM C6DB2)
27-2	2	000.00005	SCREW 2-56 X 5/8"
27-3	2	000.00022	LOCKNUT# 2-56
28	1	000.00635	TAPING SCREWS M4.2 x 9.5mm TORX
29-1	2	000.02800	LOCKNUT M5
29-2	2	000.02538	SPACER 5 x 16mm

PART LIST

30-1	1	000.02800	LOCKNUT M5
30-2	1	000.02905	FLAT WASHER M5
30-3	1	000.02538	SPACER 5 x 16mm
31-1	3	000.03095	SCREW M6 x 16 HEX
31-2	3	000.03420	LOCKWASHER M6
32	1	P8030	MICA SSRS SLOT CAP
33	1	M8250	CHARGER CAB
34	1	P8200	CHARGER LABEL
35-1	1	E2452	CHARGER CIRCUIT BHM-24B
35-2	1	000.03175	NYLON SPACER 6mm X 15mm
35-3	1	000.02915	STARWASHER M5
35-4	1	000.02800	LOCKNUT M5
36*	***1	E7510	100-120/24V 50VA TRANSFORMER
36*	***1	E7517	220-240/24V 50VA TRANSFORMER
36-2	2	000.02530	LOCKNUT M4
37	***2	C8FGMC0.5	FUSES GMC 0.5A
37	***2	C8FGMC0.250	FUSES GMC 0.250A
38-1	1	A8220	CHARGER CONTACT ASSEMBLY
38-2	4	C5CISS	CONTACT (INCLUDE IN ITEM 38-1)
39*	***1	E7525	1.5m. POWER CORD NORTH AMERICA
39*	***1	E7528	2.5m. POWER CORD AUSTRALIA
39*	***1	E7521	2.5m POWER CORD EUROPE
39*	***1	E7529	2m POWER CORD JAPAN
39*	***1	E7527	2.5m. POWER CORD U.K.
40*	***1	C5CBUL/MFC1	BULGIN 1mm 100-120V
40*	***1	C5CBUL3MM220	BULGIN 3mm 220-240V
41	1	M8200	CHARGER FRAME
42	1	001.08020	QUICK RELEASER LABEL
43*	1	P8040	CAUTION LABEL (DISCONTINUED)
44	1	P8000	VOYAGER PRODUCT LABEL
45*	1	P8010	HANDSET LABEL (DISCONTINUED)
46	1	001.08045	MANUAL LOWERING LABEL
47	2	P8015	TOUCH PAD MEMBRANE (INCLUDE WITH ITEM #1)
48	1	P8035	EJECT RED LABEL
49	1	000.01038	PLASTIC CAP
50	4	000.00635	TAPING SCREWS M4.2 x 9.5mm TORX
51	1	000.02800	LOCKNUT M5
52-1	4	000.02970	RUBBER PAD
52-2	4	000.00889	RIVET 5/32 1/8-1/4 ALUM.
53	1	A1360	VOYAGER STRAP

PART LIST

54	1	000.08000	HOOK CARIBINER
55	2	M8002	STRAP HOOK
56	2	000.02600	5 X 26 SPRING PINS
57	2	M8075	CAB UNION BRACKET
58	2	000.02548	FLAT HEAD SCREW M5 x 16
59-1	1	E0202	SWITCH-STOP LIMIT
59-2	1	000.00990	FLAT WASHER 10 x 16 x 0.5mm
59-3	1	000.00407	NUT 3/8-32
59-4	1	M8110	"SWITCH PLATE"
60	1	200.13500	TOP CHARGER
61	1	200.13510	BOTTOM CHARGER
62	4	000.02480	4 X 10mm TAP SCREW
63	1	BHM-31	BHM-31 CIRCUIT BOARD
64*	***1	402.00001	POWER CORD NORTH AMERICA
64*	***1	402.00002	POWER CORD JAPAN
64*	***1	402.00003	POWER CORD EUROPE
64*	***1	402.00004	POWER CORD AUSTRALIA
64*	***1	402.00005	POWER CORD U.K.
65	1	000.00908	RIVET 3/16 x 1/2-3/4 GRIP ALUM
66	1	000.02532	5 X 12mm NYLON SPACER
67	1	000.02905	FLAT WASHER M5 x 12mm

*** = SELECT CURRENT ACCORDING TO REGIONS.

WARRANTY

This warranty is extended only to the original purchaser/user of BHM products.

BHM Medical Inc. warrants its products to be free from defects in material under normal use and service, within the periods stated below from the date of purchase. If within such warranty period any such product shall be proven to be defective, such product shall be repaired or replaced at BHM Medical's option. This warranty does not include any labour or shipping charges incurred in replacement part installation or repair of any such product. BHM Medical's sole obligation and your exclusive remedy under this warranty shall be limited to such repair and/or replacement.

Patient Lifter	1 year
Tracks and installation	Life time warranty*
Weighing Devices	1 year
Accessories on Lifter	1 year
Slings	1 year
Batteries - Voyager Portable	3 months
Batteries - All other lifts	1 year
Easytrack System	1 year

For warranty service, please contact the dealer from whom you purchased the BHM Medical product. [In the event that you do not receive satisfactory warranty service, please contact BHM Medical (see contact information in Table of Contents).]

Do not return products to our factory without prior authorization. BHM Medical will issue a Return Merchandise Authorization (RMA) Number. C.O.D. shipments will be refused; all shipments to BHM Medical must be prepaid. For this warranty to be valid, the purchaser must present its original proof of purchase at the moment of the claim. The defective unit, assembly or part must be returned to BHM Medical for inspection. The part or components repaired or replaced are guaranteed for the remaining period of the initial warranty.

Limitations and Exclusions:

The warranty above does not apply to serial numbered products if the serial number has been removed or defaced.

No warranty claim shall apply where the product or any other part thereof has been altered, varied, modified, or damaged; either accidentally or through improper or negligent use and storage. Warranty does not apply to products modified without BHM Medical's express written consent, (including but not limited to products modified with unauthorized parts or attachments); products damaged by reason of repairs made to any component without the specific consent of BHM Medical, or to products damaged by circumstances beyond BHM Medical's control. BHM Medical will solely determine evaluation of warranty claim. The warranty does not apply to problems arising from normal wear or failure to adhere to the instructions in this manual. BHM Medical Inc. slings are void of warranty if not laundered as per instructions on the Sling Label.

BHM Medical Inc. shall not be liable for damages losses or inconveniences caused by a carrier.

This warranty replaces any other warranty expressed or implicit and constitutes BHM Medical Inc. only obligation towards the purchaser. BHM Medical shall not be liable for any consequential or incidental damages whatsoever.

* Valid only if BHM Medical did the original installation. Warranty void if tracks/installation have been modified.